



KATflow 180

Utrazvočni "clamp-on" merilnik pretoka za pline

MEASUREMENT FROM AMMONIA TO XENON

Katronic flowmeters are well established for liquid flow applications and can now be applied for the non-invasive measurement of gases. The new method not only provides measurements at high pressure gas flows but also down to atmospheric conditions even in steel

pipes which was impossible until recently. This unique innovation is achieved through advances in sensor technology, powerful sophisticated electronics, adaptive filtering techniques and innovative signal processing algorithms using Digital Signal Processors (DSP's).



Katronic

Your Solution Starts With Our Product

THE TECHNOLOGY BEHIND THE MEASUREMENT

The non-invasive measurement of gas flow is more difficult than for liquids owing to the high damping characteristics of the gaseous media. These properties mean that traditional transit-time techniques using Shear Wave sensors can only be applied for higher pressure gas pipelines. In order to successfully measure low pressure applications alternative Lamb Wave transducers should be considered instead. This method involves ultrasonic signals being excited into the pipe at the resonance frequency of the pipe wall and material which causes the pipe to become both the transmitting

and sensing device. By operating in this way higher receiving signal amplitudes can be achieved thereby compensating for the signal attenuation of the gas. The active transmission area of the pipe wall created is several times the length of the actual transducer, resulting in broader signal characteristics which allow measurements over a wider range of operating conditions. This is important as temperature, pressure and gas composition can change and the flowmeter needs to be able to adapt to these variations.

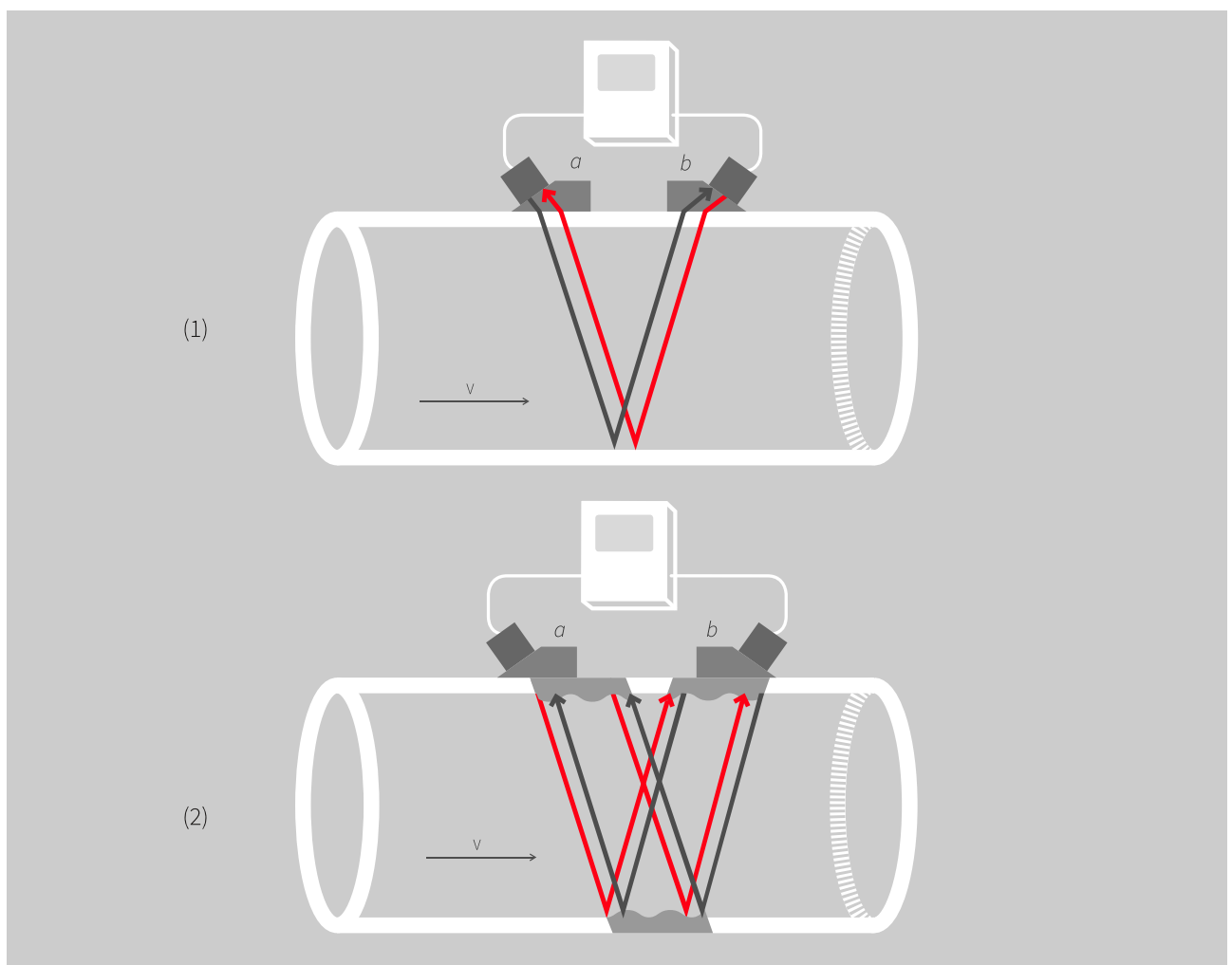

Sensors a and b work alternately to send and receive ultrasonic pulses. The sound waves travelling with the flow move faster than those travelling against it. Sensor mounting arrangements for Shear Wave (1) and Lamb Wave (2) signal evaluation shown.

Fixed

-40°C +135°C



SPECIFICATION

- Pipe diameter range 25 mm to 1V 500 mm
- Temperature range for safe area sensors -20 °C to +135 °C (-4 °F to 275 °F), for Ex-sensors -40 °C to +80 °C (-40 °F to +176 °F)
- Robust IP 66 unit with OLED display and glass-fronted keypad
- Pressure range 1 bar (absolute) to unlimited maximum
- Flow velocities 0.1 m/s to 75 m/s
- All commonly used pipe materials

FEATURES

- Suitable for installation in safe and/or hazardous areas
- Shear and Lamb Wave IP 68 stainless steel sensors
- Process output options including current, open-collector, relay
- Communication option Modbus RTU, Modbus TCP/IP
- Inputs for temperature, pressure and gas compressibility factor available
- Web-based data evaluation, instrument setup via wired, wireless or GSM connection

APPLICATIONS

- Measurement on natural gas pipelines
- Natural gas storage installations
- Control of compressor stations
- Sour gas measurements
- Synthesised gas flow measurements
- Compressed air flow measurements

MEDIA

Air, argon, carbon monoxide, ethane, ethylene, helium, hydrogen, natural gas, nitrogen, nitrous oxide, oxygen, process gas, propane, saturated steam, sour gas



FLOWMETERING SYSTEM

Performance

Measurement principle	Ultrasonic correlation transit-time difference
Flow velocity range	0.1 ... 75 m/s
Resolution	0.25 mm/s
Repeatability Accuracy	0.15 % of measured value, ± 0.015 m/s
Turn down ratio	Volume flow: $\pm 1 \dots 3$ % of measured value depending on application
Measurement rate	1/200 (equivalent to 0.35 ... 75 m/s)
Response time	100 Hz (standard)
Damping of displayed value	1 s (standard), 90 ms (optional)
Pressure range	0 ... 99 s (selectable by user)
Liquid content of gas media	0.1 MPa (1 bar) to unlimited maximum < 5 % of volume

System diagram

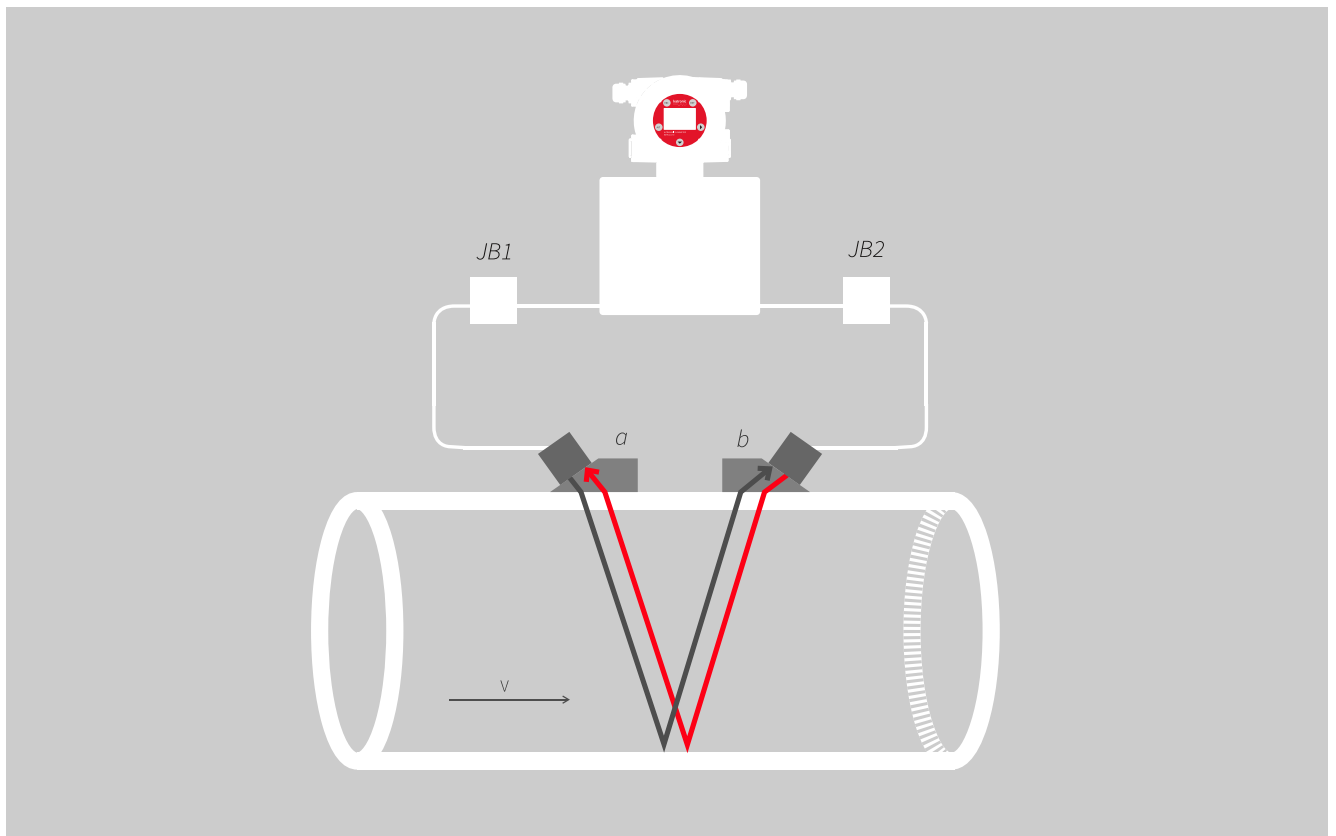

KATflow 180 system diagram

General

Enclosure type	Field housing, pipe, wall or floor mounted
Degree of protection	IP 66 according to EN 60529
Operating temperature	-20 ... +60 °C (-4 ... +140 °F)
Housing material	Copper-free aluminium, polyurethane and epoxy-coated, stainless steel (optional)
Protection concept	Flame-proof (d), increased safety (e)
Ex-certification code	II 2G Ex db eb IIB T6
Ex-certification number	EPS 11 ATEX 1355 X
Measurement channels	1
Power supply	100 ... 240 V, AC 50/60 Hz 9 ... 36 V DC Special solutions on request
Display	OLED graphic display, 128 x 64 dots, backlit
Power consumption	< 25 W
Operating languages	English (others on request)

Drawings

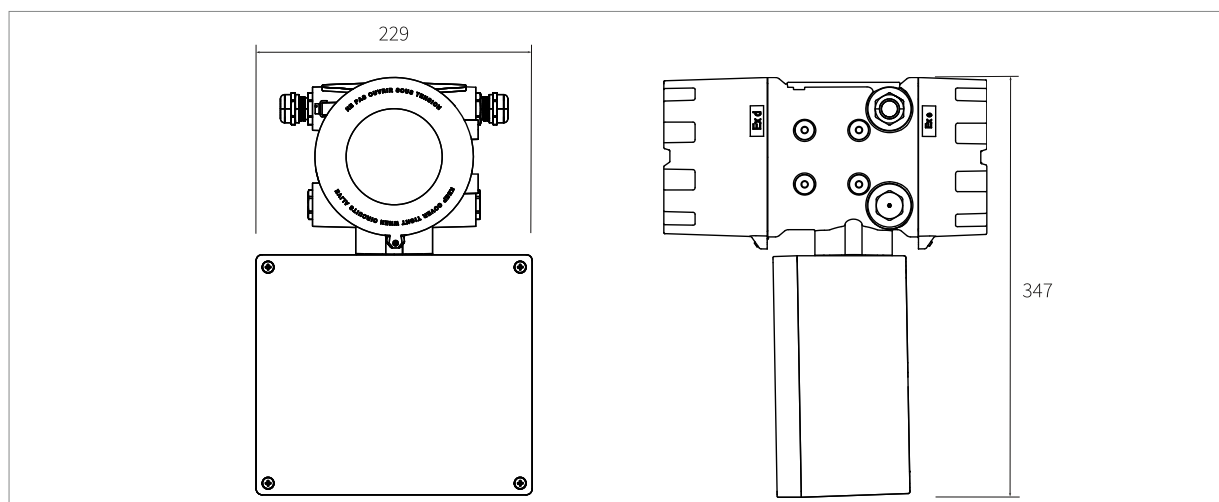

KATflow 180 (dimensions in mm)

Communication

Type	Modbus RTU or Modbus TCP/IP
Remote communication	Ethernet (wired or wireless) or GSM

Process variables

Volumetric flow rate	Standard or normalised
Gas flow normalisation	AGA8 or GERG

Process inputs (galvanically isolated)

Temperature	Pt 100 (clamp-on sensors), three- or four-wire circuit Measurement range: -50 ... +250 °C (-58 ... +482 °F) Resolution: 0.1 K Accuracy: ±0.2 K
Current (temperature, pressure, gas composition)	0/4 ... 20 mA active or 4 ... 20 mA passive, U = 30 V, R _i = 50 Accuracy: 0.1 % of measured value

Process outputs (galvanically isolated)

Current	0/4 ... 20 mA active/passive (R _{Load} < 500 Ω), 16 bit resolution, U = 30 V, accuracy: 0.1 %
Digital open-collector	Value: 0.01 ... 1000/unit, width: 1 ... 990 ms, U = 24 V, I _{max} = 4 mA
Digital relay	2 x Form A SPST (NO and NC), U = 48 V, I _{max} = 250 mA
Voltage	0 ... 10 V, R _{Load} = 1000
Frequency	2 Hz ... 10 kHz, 24 V/4 mA
HART* compatible	4 ... 20 mA, 24 V DC, R _{Load} = 220

TRANSDUCERS

G5, G10

Type G5	500 kHz (Ex and non-Ex)
Type G10	1 MHz (Ex and non-Ex)
Material of sensor heads	Stainless steel
Material of cable conduits	PTFE
Temperature range	-40 ... +80 °C (-40 ... +176 °F) (for Ex-versions) -20 ... +135 °C (-4 ... +275 °F) (for non-Ex-versions) 10.0 m
Standard cable lengths	IP 68 according to EN 60529
Degree of protection	II 2G Ex mb IIC T6 Gb
Ex-certification code Ex-	ZELM 04 ATEX 0212 X
certification number Ex-	Encapsulation (m), high level of protection (b)
protection method	

Note

The transducers are approved for use in hazardous areas classified as Ex-Zone 1 and 2. They are connected directly to the flowmeter or via extension cables and Ex-approved junction boxes.

Images



KATflow 180 and G5 type transducers in operation



KATflow 180 pipe mounted with 2" mounting frame

MOUNTING ACCESSORIES

General

Diameter range and mounting types

Mounting frame and sensor protection: DN 25 ... 250
Mounting frame and sensor protection: DN 80 ... 1V
500

Drawings and images

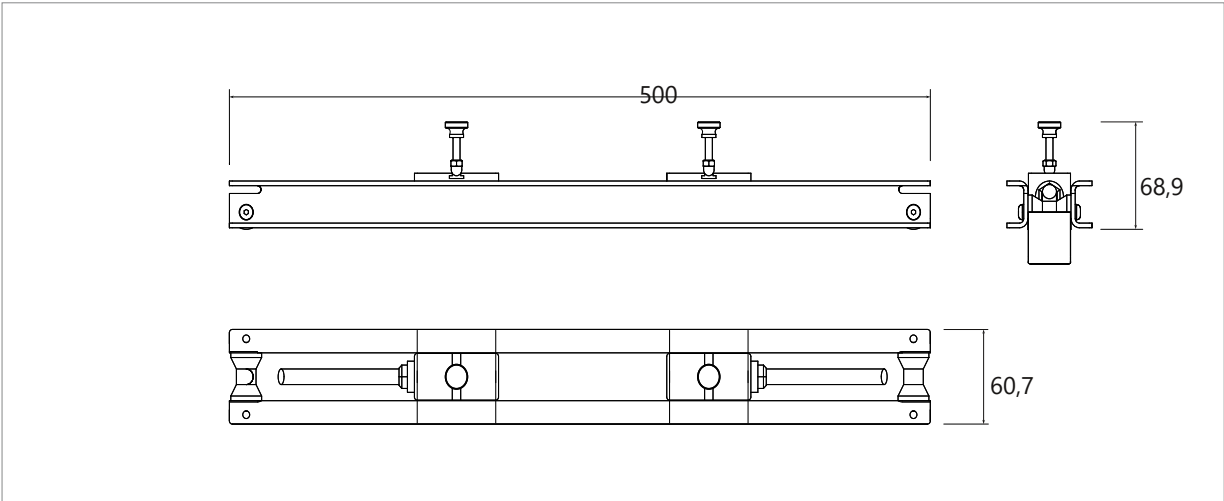

Metallic mounting rail



Metallic mounting rail with transducers



Transducer protection cover